



Slot Cars Accessories

in 1/32 scale

Racing



Ever since its foundation in 1998, Slot.it has revolutionized the slot car racing world establishing itself as the reference (and the most copied) brand for upgrade parts and competition slot cars.

Performance Universal Spare Parts



The HRS chassis is a fully configurable, universal plastic chassis for slot cars. It comprises four main parts: main chassis, front chassis, motor mount, and body mounting means.

ADJUSTABLE WHEELBASE

The front chassis can be positioned freely within a wheelbase between 64 and 90 mm.

SELECTABLE FRONT AXLE POSITION

The front axle can be placed in one of two possible positions, one of which completely adjustable, making it easy to adjust the distance from the pickup.

FLEXIBLE ASSEMBLY SYSTEM

The chassis and the body can be joined with either four mounting posts and cups (HRS1 style), two three-posts sidebars, or, on some cars, where possible, with the car's own screw holes.



Anglewinder HRS2
Ready to run HRS2 chassis
OFFSET 1,0mm

CH32

↑ 19mm ← 64 - 90mm → 55 - 63mm

1:32

Starter Kit



Sidewinder HRS2
Ready to run HRS2 chassis
OFFSET 0,5mm

CH31a

↑ 19mm ← 64 - 90mm → 55 - 63mm

1:32



CH34b

Inline HRS2 Starter Kit chassis

1:32



CH33b

Sidewinder HRS2 Starter Kit chassis

1:32



CH37

Main Inline HRS2 chassis

1:32



CH38

Main Anglewinder HRS2 chassis

1:32



CH35

Anglewinder HRS2 Starter Kit chassis

1:32

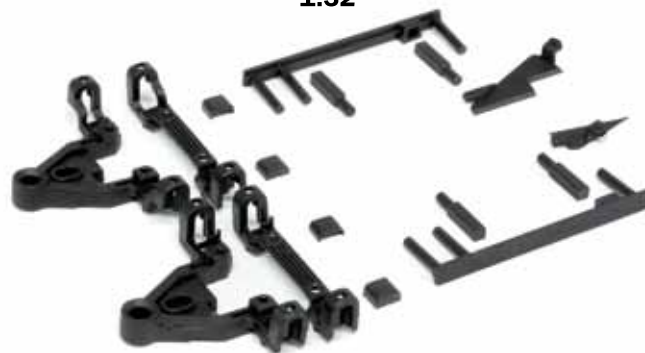

CH36

**Chassis-to-body HRS2
connecting cups and spare parts**



CH42

Clips chassis-to-body HRS2 connecting cups



CH57b

Body-to-chassis HRS2 adapter

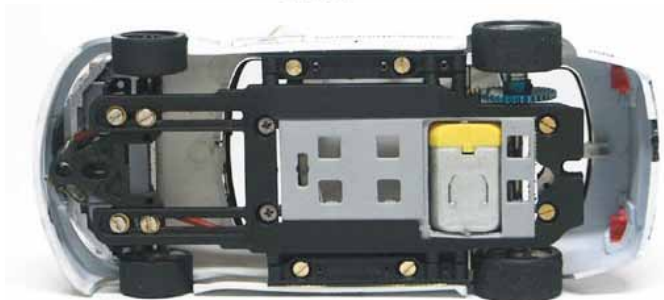

CH73

Racing Pickup
Standard Slot.it LMP models



CH66

Racing Pickup rev. B
Standard Slot.it models



CH26

Pickup Short Shaft
Standard Slot.it models



CH17

Pickup Short Shaft



CH06

Pickup Long Shaft



CH10

Pickup universal screw mount



CH07

Pickup for wooden track



Download
CH50 instructions from
www.slot.it



NEW

CH50

SCX digital adapter for HRS2 chassis

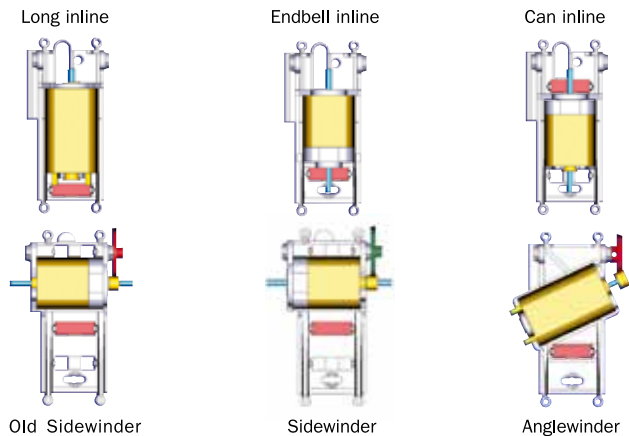

Slot.it motor mounts can satisfy all tastes and needs: can inline, endbell inline, sidewinder, long inline, Anglewinder.

Further, for each type of mount, a wide variety of **'offsets'** can be chosen.

'Offset' is the vertical difference, in mm, between the positions of the rear axle and the motor shaft.

In the **'0.0'** versions the motor shaft and the rear axle lie on the same plane, whereas in the **'offset'** versions, unique to **Slot.it**, the rear axle is offset upwards, thus lowering the center of gravity of the car and increasing the magnetic traction which either the car magnet or the motor exert on the track.

The offset distance can be 0.5 or 1.0mm in most cases.

In September 2011, for sidewinder motors, a new 0.75mm offset motor mount was launched.

Another advantage of the **'offset'** technology is that, when used jointly with wheels of 17mm of diameter, the wheels themselves stay higher in the bodywork, with a more realistic appearance.

Another unique feature of the **Slot.it** motor mount are the self-aligning gimbal bushings.

Traditional cylindrical bushings cannot compensate for chassis torsion and bad alignment; **Slot.it** spherical bushing self orient themselves to guarantee the minimum possible friction and can be made with optimal tolerances to eliminate excessive play.

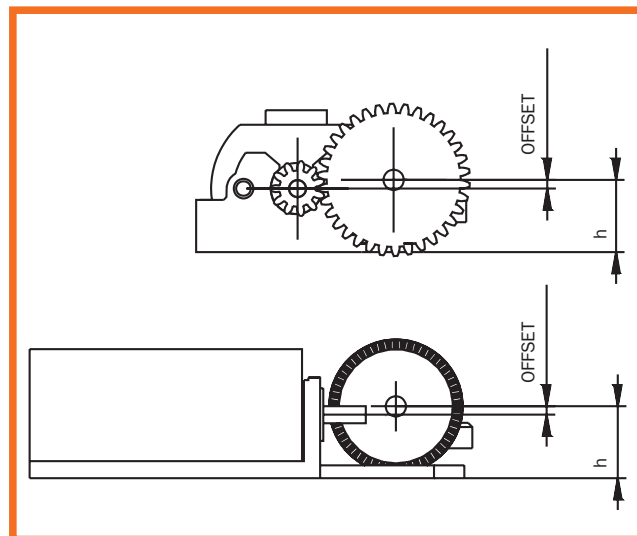

OFFSET DESCRIPTION

OFFSET (mm)	h (mm)	ITEMS
0.0	7.5	CH03b CH61 CH13b CH76 CH29 KK11 CH48
0.5	8.0	CH44b CH70 CH60 CH75 CH62 KK13b CH67
0.75	8.25	CH68 CH69
1.0	8.5	CH24b CH74 CH30 KK10 CH49 KK12b CH64 KK14b CH65

Box Stock Slot.it models



CH13b

Group C Slot.it models (2003 - 2012)

OFFSET 0.0mm



CH62

Classic Slot.it models (2011 - 20xx)

OFFSET 0.5mm



CH70

Group C Slot.it models (2012 - 20xx)

OFFSET 0.5mm



CH74

GT - LMP Slot.it models (2012 - 20xx)

OFFSET 1.0mm



CH24b

GT Slot.it models (2004 - 2011)

OFFSET 1.0mm

Group C

Classic



GT

LMP



Motor mounts OFFSET 0.0 mm



CH03b

Sidewinder for V12 motor Ø 19 spur gear



CH29

Anglewinder for Boxer / Flat-6 motor



CH76

Anglewinder for Boxer / Flat-6 motor

EV06

CH72

Plastic retainer nuts (6x)

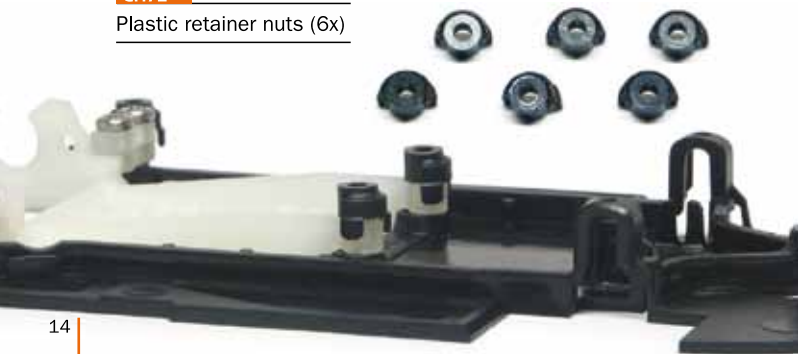

CH48

Long inline for Boxer/Flat motor



CH61

Anglewinder for Boxer / Flat-6 motor

EV06



KK11

Anglewinder Conversion Kit
Z30 AW Crowns + Z11 Ø 6,5mm Pinion

Motor mounts OFFSET 0.5 mm



CH44b
Old Sidewinder for V12 motor \varnothing 18 spur gear **OFFSET 0.5mm**



CH60
Anglewinder for Boxer / Flat-6 motor **OFFSET 0.5mm**



CH75
Anglewinder for Boxer / Flat-6 motor **OFFSET 0.5mm**



CH67
Sidewinder for V12 motor \varnothing 18 spur gear **OFFSET 0.5mm**



KK13b
Sidewinder Conversion Kit **OFFSET 0.5mm**
Z34 \varnothing 18 SW Crowns + Z11 \varnothing 6,5mm Pinion

Motor mounts OFFSET 0.75 mm



CH68
Sidewinder for V12 motor \varnothing 18 spur gear **OFFSET 0.75mm**



CH69
Sidewinder for V12 motor \varnothing 18 spur gear **OFFSET 0.75mm**

Motor mounts OFFSET 1.0 mm



CH64

Sidewinder for V12 motor Ø 18 spur gear **OFFSET 1.0 mm**



CH65

Sidewinder for V12 motor Ø 18 spur gear **OFFSET 1.0mm**

EVO6



CH49

Long inline for Boxer/Flat motor **OFFSET 1.0 mm**



CH30

Anglewinder for Boxer / Flat-6 motor **OFFSET 1.0 mm**



KK12b

Sidewinder Offset Conversion Kit
Z34 Ø18 SW Crowns + Z11 Ø 6,5mm Pinion

OFFSET 1.0mm



KK10

Anglewinder Conversion Kit
Z30 AW Crowns + Z11 Ø 6,5mm Pinion

OFFSET 1.0mm



KK14b

Flat Anglewinder Offset Conversion Kit **OFFSET 1.0mm**
Z25 Ø15 AW plastic Crown + Z11 Ø 6,5mm Pinion

The **Slot.it** motors have three different shapes: traditional 'S' can, longer '**Boxer**' type, or Slot.it's own '**Flat-6**'.

'**Inline**' means the motor shaft is perpendicular to the rear axle.

An '**inline**' motor can be either '**endbell inline**' or '**can inline**' if the pinion is either mounted near the plastic endbell, or on the other end of the motor, the metal can.

'**Sidewinder**' means that the motor runs parallel to the rear axle, i.e. transversely, and the pinion side discriminates between a '**endbell sidewinder**' or a '**can sidewinder**' like it does for inline motors.



Inline



Sidewinder



Anglewinder



Inline Boxer

The **V12** motors features a double axle, which makes it a universal motor upgrade for cars of most makers, be it endbell or can inline or sidewinder of both types.

Further, a special 'RX' adapter is available, to upgrade cars with such a 'RX' motor to a V12 one.

The '**Boxer**' type motors are an ideal upgrade for the bigger motors found on some slot cars. They can also be used as inline or 'anglewinder'.

The **FLAT-6** is a revolutionary new concept in slot car racing motors. It is a custom-built Slot.it motor designed both to be compatible with the existing Boxer/NC type motor pods, and to take advantage of a lower center of gravity when used in the special Slot.it motor pods, due to its 'slim' form, that also make it possible using it in anglewinder configuration under streamlined LMP racers like Slot.it's **Audi R8C**, **Lola** and **Audi R18**.



It comes with two magnet variants: standard, which is the strong magnet found in the V12/3 and Boxer/2, and Race 'R', with a custom built magnet to pack outstanding torque and braking in the motor's flat case.



Boxer
motor mount



Flat
motor mount



The **Boxer/2** is the most powerful Slot.it motor, used usually for 12h/24h races.



Closed can

MN08C
Boxer/2 21.500 rpm
340g*cm @12V



Open can

MN08H
Boxer/2 21.500 rpm
340g*cm @12V

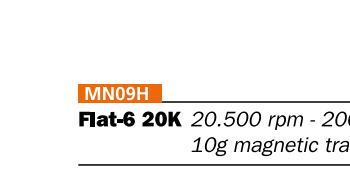

MN09H
Flat-6 20K 20.500 rpm - 200g*cm @12V
10g magnetic traction MPM



MN09C
Flat-6 20K 20.500 rpm
200g*cm @12V

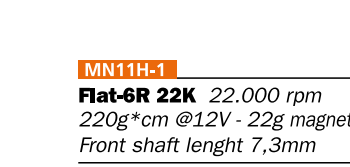

MN11H-1
Flat-6R 22K 22.000 rpm
220g*cm @12V - 22g magnetic traction MPM
Front shaft length 7,3mm

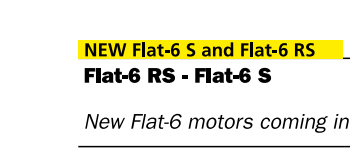

NEW Flat-6 S and Flat-6 RS
Flat-6 RS - Flat-6 S

New Flat-6 motors coming in 2012



21.500 rpm - 170g*cm @12V

MX06



25.000 rpm - 180g*cm @12V

MX07



MX: no pinion version

MS06



MS07



MS: 9 teeth pinion mounted on the endbell side of the shaft, usually for inline cars.

MF06



MF07



MF: 11 teeth pinion mounted on the endbell side of the shaft, for most sidewinder cars

MN06



MN07



MN: 9 teeth pinion mounted on the can side of the shaft, usually for inline cars.

MY06



MY07



MY: 11 teeth pinion mounted on the can side of the shaft, usually for sidewinder cars.

The V12/3 is an all new motor family from Slot.it. All the existing motor components have been studied and, when necessary, upgraded to a better specification: case, endbell, magnets and balancing have been redesigned and improved.

The result is superb torque, braking and power packaged in 'S' can motors that are also very easy to drive.

The V12 motor is an instant drop-in upgrade for most cars, thanks to its double shaft; several versions are available with the proper pinion mounted according to which car the upgrade is planned for, but any V12 motor can be changed into a different configuration just by changing pinion side and/or dimension: for example, a motor in a Scalextric configuration can be changed to an inline standard Slot.it Audi just by changing the pinion side.

MY10



MY: 11 teeth pinion mounted on the case side, for sidewinder cars

29.000 rpm - 160g*cm @12V

MX: no pinion version

MX10



MS10



MS: 9 teeth pinion mounted on the endbell side of the shaft, usually for inline cars.

MF10



MF: 11 teeth pinion mounted on the endbell side of the shaft, for most sidewinder cars

MN10



MN: 9 teeth mounted on the can side of the shaft, usually for inline cars.

SP08

Adaptor V12 to RX shape motor



The SLOT.IT extractor/press is made up of:

Main body (1) entirely made with anodized aluminium alloy designed to work with any slot electrical motor, from the most common short case to the more sophisticated, double long transmission shaft 4WD motors.

The main face was laser marked with a millimetre scale to easily control the insertion of the pinion.

Counter bushing (6) made of brass which, before using the tool, must be screwed onto the lower inside part of the main body.

The bushing has two very important functions:

- to centre the double shaft motor perfectly by means of the axle housing hole.

- to keep all those motors that are not equipped with the double shaft centred and, at the same time, safeguard the inner bush of those 'long can' motors motor that do not have an axle stub protruding from the can.

Special steel extraction plate (5) that fits in the relevant housing in the main body to extract the pinions. Besides being very resistant, this plate has a very thin eyelet located between the motor and the pinion: only 0.7 mm. This allows to extract also the pinions located very close to the motor case without causing any damage to it.

Multifunction brass tool (2) which, depending on the operation to be performed, must be inserted in the main body with the plug (steel, interchangeable, Ø1.9mm in order not to damage the pinion hole) downwards, in case of the extractor, or the pinion housing downwards, in case of the press. The pinion housing for this element were designed to house pinions with a diameter ranging from 5.5mm to 7.5mm without damaging them.

The steel plug (3) is locked into the brass tool by means of an **M3 grub screw (4)**

Advancement screw (7) on whose upper part there is an **ergonomic plastic knob (8)**, while the lower part is suitable to couple perfectly with the tool bevel, reduce friction and allow the press to operate perpendicularly without clearance.

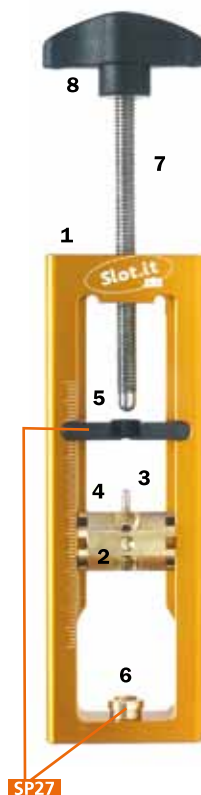

SP27

SP28



SP21

Professional Extractor Press

Ø 5,5 mm - Brass



PI08
Inline pinion 8 teeth



PI09
Inline pinion 9 teeth



PI10
Inline pinion 10 teeth



PI11
Inline pinion 11 teeth



PIMX
Inline mix pinion
8+9+10+11 teeth

Ø 5,5 mm - Internal Ø: 1,5mm



PI559o15 Pinion 9 tooth
PI5510o15 Pinion 10 tooth

Ø 6,5 mm - Brass



PS10
Sidewinder pinion 10 teeth



PS11
Sidewinder pinion 11 teeth



PS12
Sidewinder pinion 12 teeth



PS13
Sidewinder pinion 13 teeth



PSMX
Sidewinder mix pinion
10+11+12+13 teeth

Ø 6,5 mm - Ergal



PI6510e
Sidewinder pinion 10 teeth



PI6511e
Sidewinder pinion 11 teeth



PI6512e
Sidewinder pinion 12 teeth



PI6513e
Sidewinder pinion 13 teeth

**Possibly the best pinion in the world:
0.3 grams only, chemically hardened and Teflon coated**

Ø 6 mm - Brass



PI6010o
Pinion 10 teeth



PI6011o
Pinion 11 teeth

Ø 6,75 mm - Brass



PI6711o
Anglewinder pinion 11 teeth
for long hub crowns



PI6712o
Anglewinder pinion 12 teeth
for long hub crowns

Sidewinder Spur Gears

Inline Crowns



GS1934
34 teeth
for sidewinder
Ergal - Ø19 mm



GS1936
36 teeth
for sidewinder
Ergal - Ø19 mm



GS1938
38 teeth
for sidewinder
Ergal - Ø19 mm



GS1831
31 teeth
Ergal
Ø18 mm



GS1832
32 teeth
Ergal
Ø18 mm



GS1832-PI
32 teeth
Aluminium + Plastic
Ø18 mm



GS1833
33 teeth
Ergal
Ø18 mm



GS1834
34 teeth
Ergal
Ø18 mm



GS1835
35 teeth
Ergal
Ø18 mm



GS1836
36 teeth
for sidewinder
Ergal - Ø18 mm



Hex screw M2



GS06
36 teeth
Ergal
Ø18 mm



G123-bz | G123-al
23 teeth crown
Bronze/
Alumin.+Teflon



G124-bz | G124-al
24 teeth crown
Bronze/
Alumin.+Teflon



G125-bz | G125-al
25 teeth crown
Bronze/
Alumin.+Teflon



G126-bz | G126-al
26 teeth crown
Bronze/
Alumin.+Teflon



G127-bz | G127-al
27 teeth crown
Bronze/
Alumin.+Teflon



G128-bz | G128-al
28 teeth crown
Bronze/
Alumin.+Teflon



G129-bz | G129-al
29 teeth crown
Bronze/
Alumin.+Teflon



G130-bz | G130-al
30 teeth crown
Bronze/
Alumin.+Teflon



G023-bz | G023-al
G024-bz | G024-al
G025-bz | G025-al
G026-bz | G026-al
G027-bz | G027-al
G028-bz | G028-al
G029-bz | G029-al
G030-bz | G030-al

OFFSET crown
Bronze/
Alumin.+Teflon

**For OFFSET
motor mount
CH24b - CH49**

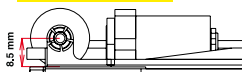

G1X1
Set 24-26-27-28-30 teeth crown - Bronze insert

ERGAL ANGLEWINDER GEAR



GA1626e

26 teeth Ø 16mm
for anglewinder
Light Ergal



GA1627e

27 teeth Ø 16mm
for anglewinder
Light Ergal



GA1628e

28 teeth Ø 16mm
for anglewinder
Light Ergal



GA1629e

29 teeth Ø 16mm
for anglewinder
Light Ergal



GA1630e

30 teeth Ø 16mm
for anglewinder
Light Ergal



GA1631e

31 teeth Ø 16mm
for anglewinder
Light Ergal



GA1832e

32 teeth Ø 18mm
for anglewinder
Light Ergal



GA1833e

33 teeth Ø 18mm
for anglewinder
Light Ergal



GA1834e

34 teeth Ø 18mm
for anglewinder
Light Ergal



GA1835e

35 teeth Ø 18mm
for anglewinder
Light Ergal



GA1836e

36 teeth Ø 18mm
for anglewinder
Light Ergal



PA25

Stopper for anglewinder axles
Aluminium+teflon



GA34

34 teeth for
Anglewinder
Ergal



GA36

36 teeth for
Anglewinder
Ergal



GA24LH

24 teeth gear



GA26LH

26 teeth gear

FLAT ANGLEWINDER GEAR LONG HUB

Ø 15mm PLASTIC ANGLEWINDER GEAR



GA1524-Pl

24 teeth for Flat Anglewinder
Aluminium + Plastic



GA1525-Pl

25 teeth for Flat Anglewinder
Aluminium + Plastic



GA1526-Pl

26 teeth for Flat Anglewinder
Aluminium + Plastic



PA57

Light aluminium Stopper
for anglewinder setup (2x)

NEW

Wherever a **Boxer** can be mounted as anglewinder, a **Flat-6** can be used as well.

So: all group C cars and all GTs (not LMP) can be used as anglewinder with both the Boxer or the Flat-6. The LMPs (**Audi R8C**, **Lola LMP** and **Audi R18**) can be used as anglewinder with a Flat-6 motor only (this applies to Scaleauto Radical and Scaleauto Toyota GT1 as well).

To fit an anglewinder plastic crown on a **Audi R8C LMP** use either a 6.5mm pinion with a 15mm diameter crown (**GA1524/25/26pl**) with 1mm spacer or a 6.0mm pinion with a 16mm crown (**GA1627/28/29pl**) and a 0.75mm spacer.

In the **Lola LMP** and **Audi R18**, a 6.5mm pinion can be used with 16mm plastic crowns as well, and 0.1mm, or no spacer at all.

26 - 27 - 28 - 29 - 30



31 - 32 - 33 - 34 - 35 - 36

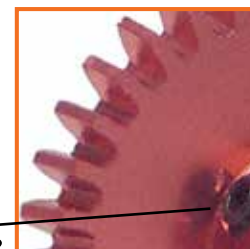

Hex screw M2



NEW

KK04
Kit sidewinder
 Z36 Ø19 crown
 Large hubs



NEW

KK02
Kit sidewinder
 Z36 Ø19 crown
 Small hubs



NEW

KK05
Kit sidewinder
 Z34 Ø18 crown
 Small hubs



KK09b
Kit anglewinder
 Z32 crown + pinion
 Large hubs



Steel ProAxle rectified and tempered - 2.38 mm (3/32")

PA01-45 45 mm **PA01-51** 51 mm
PA01-48 48 mm **PA01-54** 54 mm



Steel ProAxle hollow rectified and tempered - 2.38 mm (3/32")

PA01-54H 54 mm

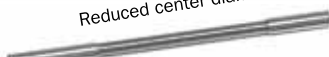

Reduced center diameter

Steel ProAxle rectified and tempered for sidewinder 2.38 mm (3/32")

PA01-48R 48 mm **PA01-54R** 54 mm
PA01-51R 51 mm



PA39
 Independent front wheels axle



SP17
Brass eyelets for independent front wheels axle (x10)



KK01
Kit inline Z28 crown - Small hubs



KK07
Kit inline Z28 crown - Large hubs



KK08
Kit inline Z27 crown - Plastic small hubs



KK06
Kit inline Z24 crown F1 hubs



KK03
Kit inline Z26 crown + pinion - Large hubs for Carrera



Aluminium

Ø 14,3x8 mm



PA33-Als

Short hub light wheels
Aluminium 1.2g - (2x)



Magnesium



PA33-Pl

Short hub light wheels Plastic
0.57g + Plastic inserts - (4x)



Long hub light wheels

Ø 14,4x11,5 mm



PA20-Als

F1 hubs + Plastic inserts
BBS type
Aluminium 1.5g - (2x)



Short hub light wheels



PA20-Mg

F1 hubs - Magnesium 1.0g - (2x)

Ø 15,8x8,2 mm



PA17-Pl

Hubs + Plastic inserts OZ type
Plastic grey - (4x)



PA17-Al

Hubs + Plastic inserts OZ type
Aluminium 1.4g - (2x)



PA17-Mg

Short hub light wheels
Magnesium 0.9g - (2x)



PA24-Als

Short hub light wheels +
Plastic inserts OZ type
Aluminium 1.4g - (2x)



PA24-Mg

Short hub light wheels
Magnesium 0.8g - (2x)



PA24-Alf

Short hub light wheels
double shoulder
Aluminium 1,2g (2x)



PA24-Alh

Short hub light wheels
double shoulder holed channel
Aluminium 1,1g (2x)

Ø 15,8x10 mm



PA49-Alf

Short hub light wheels
double shoulder
Aluminium 1,3g (2x)



PA49-Alh

Short hub light wheels
double shoulder holed channel
Aluminium 1,2g (2x)

Ø 16,5x8,2 mm



PA43-Als

Short hub light wheels + Plastic inserts OZ type - Alu. 1.5g - (2x)



PA43-Mg

Short hub light wheels
Magnesium 0.8g - (2x)



PA43-PI

Hubs + Plastic inserts OZ type
Plastic grey - (4x)

Ø 17,3x10 mm



PA19-Als

Hubs + Plastic inserts BBS type
Aluminium 1.7g - (2x)



PA19-Mg

Short hub light wheels
Magnesium 1.05g - (2x)

Ø 17,3x8,2 mm



PA18-Als

Hubs + Plastic inserts BBS type
Aluminium 1.6g - (2x)



PA18-Mg

Short hub light wheels
Magnesium 0.9g - (2x)



PA18-PI

Hubs + Plastic inserts BBS type
Plastic black - (4x)



PA38-Als

Short hub light wheels +
Plastic inserts BBS type
Aluminium 1.6g - (2x)

PLASTIC INSERTS



PA09b Black



PA09s Silver



PA09g Gold

Wheel inserts for hubs Ø17,3 - BBS type - (4x)



PA36

Plastic inserts for hubs Ø17,3
OZ type Black - (4x)



PA42

Plastic inserts for hubs Ø17,3
Ferrari F40 type Silver - (4x)



PA56

Wheel inserts BBS type for
hubs Ø17,3 PA18/19/38 - (4x)



PA46

Wheel inserts for hubs Ø15,8
for PA17/24 - (4+4x)
Ford GT40 type



PA44

Plastic inserts for hubs Ø15,8
Mazda 787B type - (2+2x)



PA30

Plastic inserts for hubs Ø15,8
Sauber C9 type black (4x)



PA16

Plastic inserts for hubs Ø15,8
OZ type - (4x)

PLASTIC INSERTS



PA55

Wheel inserts BBS 80's type for hubs PA17/24 (4x) - PA43 (2x)



PA53

Wheel inserts Lancia LC2-85 type for hubs PA17/24 (4x) - PA43 (2x)



PA41

Plastic inserts Alfa Romeo (2x for hubs Ø15,8) Silver (2x for hubs Ø14,3) Silver



PA48

Wheel inserts Toyota 88C type for PA17/24 - (4x) Ø15,8 for PA43 - (2x) Ø16,5



PA35

Plastic inserts Ferrari 312 PB (2x for hubs Ø15,8) Gold (2x for hubs Ø14,3) Gold



PA45

Plastic inserts for hubs Ø15,8 Chaparral 2E (4x) Silver



PA31

Plastic inserts for hubs Ø15,8 Jaguar XJR type Black - (4x)



PA34

Plastic inserts for hubs Ø15,8 Lancia LC2 type Black - (4x)



Wheel inserts for hubs Ø14,4 BBS type - (4x)

PA13b Black **PA13s** Silver
PA13g Gold



Wheel inserts for hubs Ø15,8 BBS type - (4x)

PA03b Black **PA03s** Silver
PA03g Gold

Slot.it provides a comprehensive range of tires for the racer and the scale modeler alike.

There's a high performance compound for every track surface, and a wide variety of sizes to choose from.

The latest addition is the high performance rubber N22.

Whenever possible, the sidewall is engraved with a reference number to help tire identification.



Low profile front tire

High grip rear tire

Realistic threaded rear tire



Engraved sidewall



Classic cars replacement tires

TYRE SELECTION TABLE

Compound	Track Type
C1	Ninco - Scalextric
P2 - P3	Non abrasive (smooth plastic, smooth wood)
P4 - P5 - E1 - C1	Ninco
P6	Scalextric Sport - Carrera - Wood
S1 - S2	Non abrasive and clean
Z0 - Z1	Front wheels only
F15 - F22 - F30 - N22	Any

Carrera, Ninco, Scalextric trademarks belong to their respective owners.

How to use the cross-reference table:

- 1: if you know the code for the tyre: locate the code in the bottom half of table B, then read the mould code at the top of the same column if you don't, search for a small number engraved on the side wall of the tyre - that's the mould code (old tyres don't have it)
- 2: if you know the code for the wheel find, the its reference letter (A through G) on table A
if you don't, measure the diameter of the wheel, and read the corresponding code (A through G) on table A
- 3: 3 - Cross the reference letter and the tyre mould code to find out the cross-compatibility between your tyre and wheels, and the resulting diameter

Example: you have a PA38 wheel, and a PT19 tyre:

- 1st step Table B: search PT19: see that it comes from mould 1096
- 2nd step Table A: search PA38: see that it belongs to the 'F' family of wheels
- 3rd step Table B: crossing 'F' with '1096': resulting diameter is 18.1mm.

Width according to tyre size

all dimensions are in mm

	14.3*8.0	14.4*11.5	15.8*8.2	15.8*10	16.5*8.2	17.3*8.2	17.3*10
PA33	A						
PA20		B					
PA17, PA24			C				
PA43				E			
PA19						G	
PA18, PA38						F	
PA49				D			

A

Tyres used on box stock cars	
1027C1	Front GT and Gr.C. C1 tyre never sold as spare, replaced by PT34 (GT) and 1159C1 (Gr.C)
PT17	Rear Gr.C and Classic box stock. Now replaced by PT35.
PT18	Rear GT box stock. Now replaced by PT1152C1
PT20	312PB and Alfa33 front, box stock
PT32	Front and rear threaded, Classic tyres (Chaparral, GT40,...). Code will change to PT2120C1
PT33	Same mould as PT17, but in S2, was under the base of the car
PT34	GT front. Now replaced by PT1159C1
PT35	Rear Gr.C and Classic (slick) box stock. Will be replaced by future 1167C1.
PT1152C1	Rear GT box stock. Also used temporarily on Gr.C with 16.5mm wheels
PT1159C1	Front GT and Gr.C
PT1167C1	Future Gr.C for 16.5mm wheel
PT2120C1	Composite pack, two 1121(front classic threaded), two 1120 (rear classic threaded), C1 compound

REFERENCE BY MOULD CODE/TYRE CODE

mould code	1027	1028	1042	1045	1046	1067	1068	1088	1096	1120	1121	1140	1152	1159	1167	1170	1171	1172	
tyre width	10,0	11,2	10,5	10,0	10,5	10,0	12,4	8,0	8,0	10,5	10,0	9,5	10,5	9,5	10,0	9,5	10,0	11,3	
A	-	-	-	-	-	-	-	17,0	15,1	-	-	-	-	-	-	17,1	-	-	
B	-	-	-	-	-	-	20,8	-	-	-	-	-	-	-	-	-	-	-	
C	19,0	19,7	19,7	18,8	-	17,0	-	18,4	16,7	19,9	19,4	20,1	19,0	18,3	19,1	18,5	19,7	19,9	
D	19,0	x	x	x	-	-	-	-	-	19,9	19,4	x	19,0	-	-	-	19,7	19,9	
E	19,6	20,3	20,2	19,4	-	17,6	-	19,0	17,3	20,5	20,0	20,6	19,6	18,9	19,6	19,1	20,3	20,4	
F	20,2	21,0	20,8	20,1	20,2	18,3	-	19,7	18,1	21,2	20,7	21,3	20,3	19,4	20,3	19,8	21,0	21,1	
G	20,2	21,0	20,8	20,1	20,2	18,3	-	19,7	18,1	21,2	20,7	21,3	20,3	19,4	20,3	19,8	21,0	21,1	
PT04 PT05 PT06 PT07 PT08 PT09 PT10 PT11 PT12 PT22 PT21 PT24	PT01 PT02 PT03 PT04 PT05 PT06 PT07 PT08 PT09 PT10 PT11 PT12 PT13 PT14 PT15 PT16 PT17 PT18 PT19 PT20 PT21 PT22 PT23 PT29	PT09 PT10 PT13	PT33 PT17	PT34	PT18	PT15	PT13 PT14 PT16 PT23 PT29	PT20	PT19	PT19 PT210C1 PT2120C1	PT32 rear PT2120C1	PT35	PT35	PT1152C1	PT1159C1	PT1167C1	PT1170E1 PT9670E1	PT126 PT127 PT128 PT111N22	PT30 PT31 PT117N22

B

REFERENCE BY COMPOUND

P1	P2	P3	P4	P5	P6	Z0	Z1	F15	F22	F30	C1	E1	S1	S2	N22
PT01 PT04	PT02 PT05	PT09 PT10 PT13	PT11 PT12 PT14	PT21 PT22 PT23	PT24 PT25	PT07 PT15	PT19	PT26 PT30	PT27 PT29 PT31	PT28	PT23 PT32 PT33 PT34 PT35 PT2120C1 PT1159C1 PT1152C1 PT1167C1	PT1170E1 PT9670E1	PT03 PT06 PT16	PT17 PT18	PT117N22 PT1172N22

- discontinued



PA02
Bronze bushings - (2x)



PA11
Bronze bushings for Proslot - (2x)



SP19
Copper braid - 1 m



SP18
Tin plated Copper braid - 1 m



PA32
Aluminium bushings
Aluminium+Teflon - (2x)



PA12
Brass bushings
old Carrera - (2x)



SP04
Motor cable brass eyelets (10x)



SP22
Silicon cables high flexibility (1m)



CH56
Brass bushings HRS chassis
Standard Slot.it models - (6x)



PA27
Bronze bushings
Double side - (4x)



CN01
Neodimium Super Magnet
for Scalextric - 25x8x2mm



CN02
Neodimium Progressive
Super Magnet for Scalextric
25x8x2,3mm



CH77
Aluminium End of Run Nuts
(2x)



PA26
Machined pulley
Plastic CNC - (2x)



PA28
Machined pulley
Aluminium - (2x)



CN06
HRS chassis Neodimium Magnet



CN07
HRS chassis Race Magnet



CN08
Neodimium Magnet for magnetic
suspension kit - Ø 4x1mm (8x)



CN09
Neodimium Magnet for magnetic
suspension kit - Ø 4x1.5mm (8x)

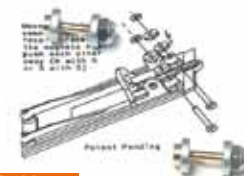

CH09
Magnetic suspension kit

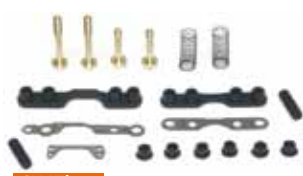

CH47b
Universal spring suspension kit



SP23
Tungsten ballast
motor mount
shape 2,5g



SP25
Tungsten ballast,
putty, 10g

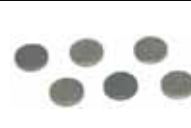

SP24
Tungsten ballast
cylinder 6,3x1mm
0,6g



CH55A
Soft springs
for CH47b suspension (x8)



CH55B
Medium springs
for CH47b suspension (x8)



PA58
Hexagonal Screws M2 x 2mm (x10)



PA40
Hexagonal Screws M2 x 3mm (x10)



PA37
Hexagonal Screws M2 x 6mm (x10) for front axle setup



PA50
Hexagonal Screws M2 x 8mm (x10) for front axle setup



PA54
Hexagonal Screws M2 x 10mm (x10) for front axle setup



PA06
Hexagonal wrench M2 0,95 mm



PA22
Hexagonal screwdriver M2 0,95 mm



PA23
Fixed Torque Key hexagonal M2 0,95 mm - Dynamometric

PA51
Set of spacers for hubs 1mm (x10)



PA52
Set of spacers for hubs 0,75mm (x10)



PA47
Set of spacers for hubs and bushings - 0,1 / 0,25mm thick



CH54b
Metric screws 2.2x5.3mm large head (10x)



CH59
Set of suspensions screws L9mm + L13mm (2+2)



CH51
Screws 2.2x8mm Small head (10x)



CH52
Screws 2.2x8mm Big head (10x)



CH53
Screws 2.2x5.3mm Small head (10x)



CH54
Screws 2.2x5.3mm Big head (10x)



CH28
Set of screws for Cars (8 short - 4 long)



CH08
Set of screws for HRS chassis



CH41
Replacement Motor Fixing Screws (10x)



CH39
Set of screws for HRS2 chassis

Model / Serie	Chassis	Crashproof
		
Audi R8C	CA01	CS01T-2
Porsche 956 C	CA02	CS02T-60
Porsche 962 C	CA03	CS03T-60
Nissan R390 GT1	CA04/05	CS14T-60
Sauber C9 Mercedes	CA06	CS05T-60
Jaguar XJR9	CA07	CS13T-60
Lancia LC2-84	CA08	CS08T-AW / CS21T-60
Porsche 956 KH	CA09	CS09T-60
McLaren F1 GTR	CA10	CS10T-60
Alfa Romeo T33/3	CA11	CS11T-60
Audi R8C Reloaded	CA12	CS12T-60
Jaguar XJR12	CA13	CS13T-60
Nissan R390 GT1 LT	CA14	CS14T-60
Mazda 787B	CA15	CS15T-60
Chaparral 2E	CA16	CS16T
Porsche 962C KH	CA17	CS03T-60
Ford GT40	CA18	CS18T-60
Toyota 88C	CA19	CS19T-60
Ford MK II	CA20	CS18T-60
Lancia LC2-85	CA21	CS21T-60
Lola B09/60	CA22	CS22T-60
Ferrari 312PB	KF01	KS01T
Ferrari F40	KF02	KS02T

Transparent parts	Lexan cockpit	White kit	Body kit
			
CS02V	CS02il		CS02b
CS02V	CS02il		CS03b
CS04V	CS04il	CA14z	CS14b
CS05V	CS05il	CA06z	CS05b
CS07V	CS07il		CS07b
CS08V	CS08il	CA08z	CS08b
CS02V	CS02il		CS09b
CS10V	CS10il		CS10b
CS11V			CS11b
CS12V	CS12il		CS12b
CS07V	CS07il		CS13b
CS04V	CS04il	CA14z	CS14b
CS15V	CS15il		CS15b
CS16V			CS16b
CS02V	CS02il		CS17b
CS18V	CS18il		CS18b
CS19V	CS19il	CA19z	CS19b
CS18V		CA20z	CS20b
CS21V	CS08il	CA21z	CS21b
CS22V	CS22il	CA22z1/CA22z2	CS22b1/CS22b2
KS01V			KS01b
KS02V	KS02il		KS02b



SP07
Spacers for chassis



SP09
Transparent box for car



TM01
Pitlane Girls



Body Kit



SP11

Lighting Kit - 2 white front + 2 rear red lights module



SP16

Universal Lighting Kit for Analogic and SSD Slot.it cars



SP06

Lighting Kit with brake - SP06 = SP10+SP11



SP26

Switch and mixed electronic parts for lighting Kits - SP06 and SP16



SP10

Lighting Kit - Base module



SP12

Hornby SSD upgrade



Electronic Controller

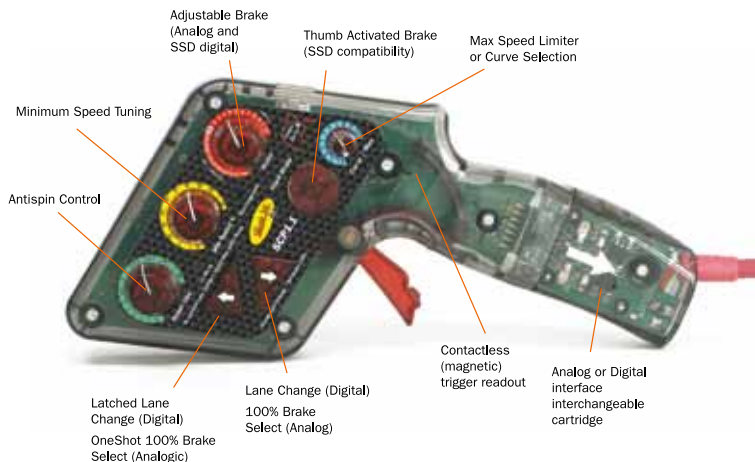

● **Telemetry Data Interface (*)**

● **Ghost Car Motor Test Mode**

SCP01a
Electronic Controller Analog

CARTRIDGES / CONTROLLER COMPATIBILITY FOR SCP-1					
Analog					
	Ninco	SCX (old connector)	SCX (jack connector)	Carrera	Scalextric
SCP01b Cartridge SCP01g Cartridge SCP01a Controller Analog Common Ground	S	S	S	S	X
SCP01c Cartridge SCP01i Controller Analog Common Positive	V	S	X	S	V
Digital					
	Ninco	SCX	Carrera	Scalextric	
SCP01e Digital Cartridge SCP01d Digital Controller	V	V	V	X*	
SCP01e-3v3 Digital Cartridge SCP01d-3v3 Digital Controller	X	V	X	V*	

V = Box-stock compatible. No wiring necessary
 S = Compatible but requires soldering of different connectors
 X = Not compatible
 X* = For all system except Hornby C7042
 V* = Compatible ONLY with Hornby C7042
Common Ground = Positive Wiring
Common Positive = Negative Wiring

Carrera, Ninco, SCX, Scalextric trademarks belong to their respective owners.



SCP01d
Digital Controller
 (all system EXCEPT Hornby C7042)



SCP01i
 Controller analog
 Homeset version (Hornby - Ninco)



SCP01h
Digital Controller - oXigen cartridge



SCP01m
Digital Controller
 oXigen cartridge - Live Timing Box



SCP01d-3v3
Digital Controller
 (ONLY Hornby C7042 / SCX Digital)



SCP01f
 Controller without Cartridge



SCP01b
 Analog Common Ground
 (Positive Wiring) Cartridge



SCP01g
 Analog Common Ground
 (Positive Wiring)
 High Current Cartridge
 20A cont. - 40A peak



SCP01c
 Analog Common Positive
 (Negative Wiring) Cartridge



SCP01e

Digital Cartridge - (all system EXCEPT Hornby C7042)



SCP01e-3v3

Digital Cartridge - (ONLY Hornby C7042 / SCX Digital)



SCP04e

Replacement silicon cable



SCP04a

Complete Trigger Set



SCP02a

Complete Red Shell



SCP03a

Spare Red plastic parts



SCP02b

Complete Blue Shell



SCP03b

Spare Blue plastic parts



SCP02c

Complete Yellow Shell



SCP03c

Spare Yellow plastic parts



SCP04c

Replacement fuses for SCP-1
3. 15A - fast (5x)



SCP04d

Replacement retriggerable
fuse for SCP-1 - 1,35A (x1)



Live Timing System

Supported by PC Lap Counter
Directly compatible with oXigen

Slot.it

Live Timing Box is an innovative timing system that allows to:

- reproduce via audio the lap times recorded by the pilot, in a language to be chosen among many;
- store in the device's internal memory the times heard on earphones, sector times and, in case, the telemetry data of the SCP controller of Slot.it to which it is connected;
- listen to your favourite music while driving, by connecting the **Live Timing Box** to a MP3 player through a normal audio cable not included in the package;
- download the stored data that can be looked up by the user from a PC by means of a special program downloadable for free (we're generous, aren't we?) at www.slot.it (Live Timing Box PC Interface);
- updated the system software, with the opportunity to add new specifications to the **Live Timing Box** in the future without any additional charge;
- delete stored data (good idea);
- remember the status of data storage button and mute button so that it is not necessary to repeat the setup carried out before the supply was cut off.
- work as a complete Race Management System when used in conjunction with appropriate RMS software (e.g. PCLapCounter).

Moreover, **Live Timing Box** is a versatile system, since its functioning requires only the presence of the **Track Interface** and is **totally independent of the kind of controller employed**.

The presence of the **Track Interface** is necessary since the latter has the job of interfacing the **Live Timing Box** with the track by collecting the signals coming from the sensors on the circuit (DS bridge, dead strips, Winchono,...) and sending them after suitable elaboration to the **Live Timing Box** itself.

For further information concerning the Track Interface system, see the relative manual.

FOR ANY TYPE
OF CONTROLLER



TS01a

Live Timing Box



TS02a

Track Interface



TS02b

Track to Telemetry cable



TS03a

Sector Time Expansion cable



Live Timing Box PC
Interface Software.

Track Interface

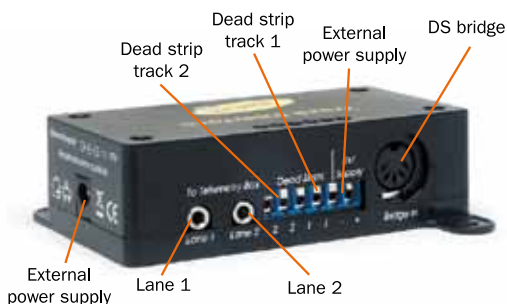
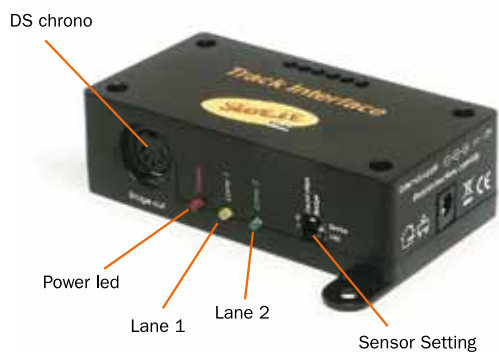

The **Track Interface** is a system having the job to interface the **Live Timing Box** to the sensors (DS bridge, dead strips...) which are on the track. In particular, it elaborates the signals given by the sensors so that they can be read by the **Live Timing Box**, allowing the latter to carry out the expected functions, such as: lap time playback and time and telemetry data storage.

Each **Track Interface** is able to manage the signals coming from two lanes, up to a maximum of two sensors per lane (e.g. a dead strip and a DS bridge), allowing the user to choose the lap counter sensor and the sector time sensor.

Live Timing Box

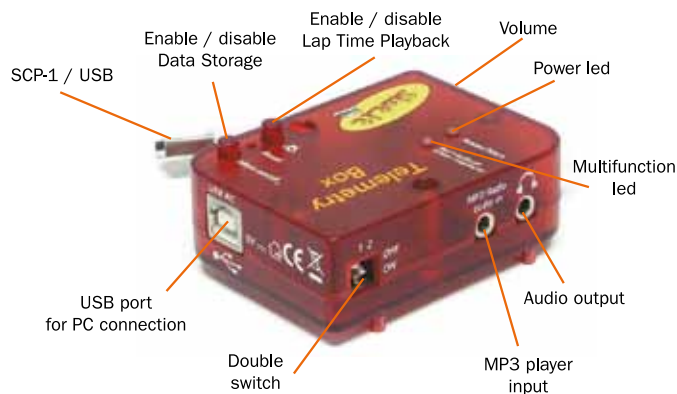

For further information concerning the **Track Interface** system, see the relative manual.



OXIGEN Digital System



Available NOW

Slot racing digital system

Compatible with existing analog tracks

2.4GHz Wireless. 20 cars per track, up to 4 tracks

Open interface

oXigen digital systems bridge the gap between analog and digital racing.

Designed, developed, supported by Slot.it, the reference company for Slot Car Racing, **oXigen** turns quickly digital racing into reality without losing compatibility with traditional analog racing on the same track.

Cars are controlled by radio and take their power from the track.

This creates a clean communication between the car and its controller, and at the same time poses no restriction on the track power. Lane changing is based on the robust and well tested SSD LED protocol developed by Hornby (used under licence).

oXigen accessories like lane changers actually work very well with SSD cars.

Specific modules can turn lane changers from Ninco and Carrera into **oXigen** or SSD lane changers, at small cost.



Type A



Type B



Lane Change

- O₂ track pieces for Scalextric track
- O₂ LC parts can be used inside Scalextric SSD systems (under licence from Hornby)
- Upgrade electronics for Ninco and Carrera lane changers

More oXigen

- A whole new dimension for club slot car racing
- Maintain your existing investment AND analog racing
- Easy setup
- Developed and supported by Slot.it



Oxigen software.

*Requires USB/RF dongle.

- Compatible with SCP-1
- Open PC protocol for third party software
- Supported by PCLapCounter
- Available NOW!

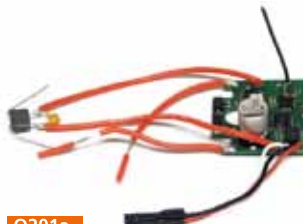

O201a

oXigen chip In-car controller (type A)



O201b

oXigen chip In-car controller (type B)

O202a

oXigen Radio cartridge



O203a

oXigen Lane changer driver for Ninco/Carrera



O204a

oXigen Dongle



O205a

oXigen Battery holder



Polo m

Slot.it Polo - Shirt for Man

S / M / L / XL / XXL



Polo w

Slot.it Polo - Shirt for Woman

S / M / L

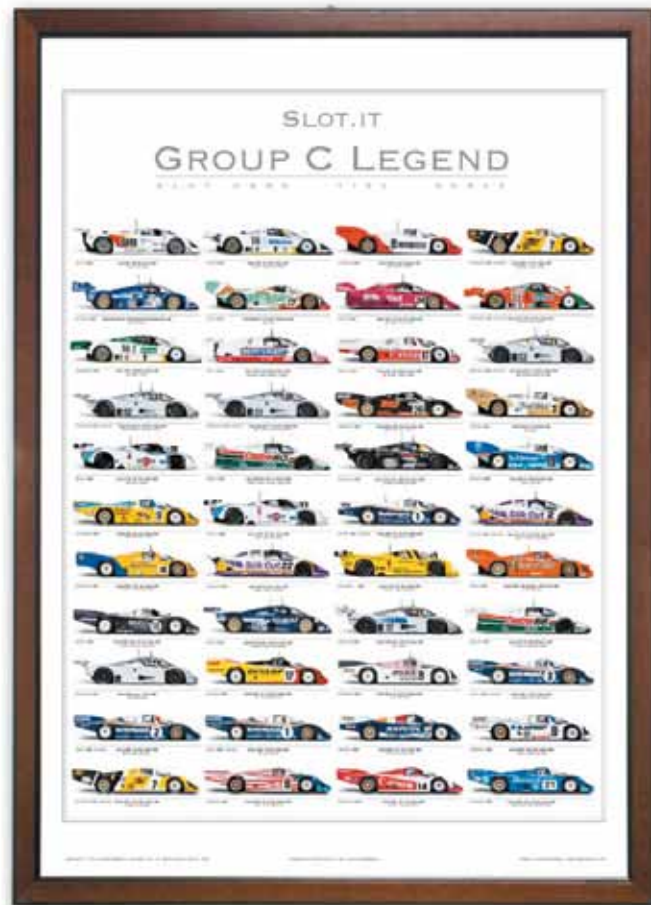

Group C is, without doubt, a category which has become synonymous to **Slot.it**. Slot.it has come a long way since 2003, when the first Gr.C car, the Porsche 956 Kenwood, was launched.

We've lost count, since then, of how many other models have been made. It was 9 years of success, racing, collecting, which turned the Italian company into a reference name in the world of slot cars.

A limited edition lithography was printed, on special drawing paper, in 70x100cm size, reproducing in historical order all the Gr.C cars which were made to celebrate these first nine

years, was printed. The images, real pictures of the cars, are in 1:1 scale, hence, optical distortions permitting, are a faithful scale reproduction of the **Slot.it** model.

The caption for each model shows the selling date, production code, and other information like the name of the car, the race venue and date, and the driver's names.

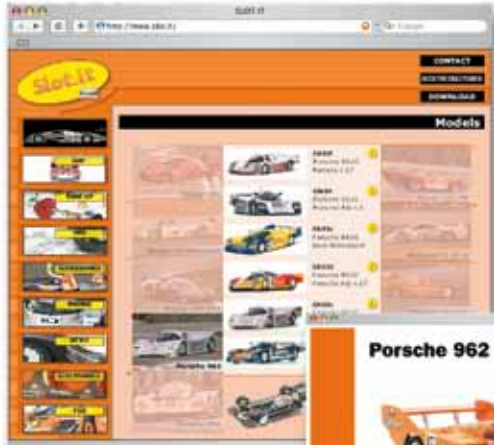

More information available on our website www.slot.it



ITALY

Model Assistance srl
Via Guadiana 24
42124 Reggio Emilia
Tel. +39 0522 942873
Fax +39 0522 942874
info@modelassistance.it
info@radiokontrol.it

AUSTRALIA

Armchair Racer
1/18-20 Hotham Parade
Artarmon NSW 2064 Australia
Ph: +61 2 9906-5566
Fax: +61 2 9906-2200
cathy@armchairracer.com.au
www.armchairracer.com.au

BENELUX

Q.U.I.C.K.
Victoria Regiastraat 32
1338 ZA - Almere
Nederland
Tel.+31 365370853
Fax +31 365328801
www.quickholland.com
fred.quick@tip.nl

BRAZIL

B52 Autorama
Pca. Floresta, 310 ap 06
Santo André
São Paulo 09050-090
Brazil
b52grp7@gmail.com

CZECH REPUBLIC - SLOVAKIA

Jana Zednickova
Chrastany 5 Podesice
411 15 Trebivice
Czech Republic
tel +420 475 205 600
info@autodrahy.info
www.autodrahy.info

FRANCE

Fair International
23 avenue Jules Vedrine
44300 NANTES
Tel. 09 62 36 34 09
Port. 06 13 50 10 77
Fax. 02 40 59 28 15
fairslot@wanadoo.fr

GERMANY - AUSTRIA

H+T Motor Racing GmbH
Bert - Brecht - Strasse 43
D - 64291 Darmstadt - Deutschland
tel. +49 (0) 6150 - 84801/84802
Fax +49 (0) 6150 - 84803
info@hmtorracing.de
www.slotracingteam.de

GREECE

Creative Hobby
17 Vrillission str.
15236 Pendeli
Athens, Greece
Tel./fax +30-210-6135518
www.creativehobby.gr
nisko@creativehobby.gr

JAPAN

Project Co. Ltd
14-10 Takatsuji cho Mizuho ku
467 - 0872 Nagoya
Tel. +81 052-883-0222
Fax +81 052 883-0777
sw32@museo500.com
www.museo500.com

Beaver Co.
No. 8-5 Matsushima 4-chome
Endogawa-ku - 132-0031 Japan
Tel. +81 3 3655 5300
Fax +81 3 3655 3115
beavercorp@dune.ocn.ne.jp

MALTA

Simon Models
Gizimina 22 - Tower Promenade
Santa Lucija SLC1017
Tel: 000356 21664568
Mob: 000356 79300991
nicholas_slot,it@hotmail.com
www.simonmodels.com

MEXICO

Modelismo Team S.A. de C.V.
Av. Insurgentes Sur 1352, L-148
COL. del Valle, Mexico D.F. 03100
Tel/Fax 5534 0177
www.modelismoteam.com.mx
modelismoteam@prodigy.net.mx

NEW ZEALAND

Burmac Ltd
42 Pinotage Drive, Oakland Estate
4112 Napier
Tel. +64 6 844 8870
Fax +64 6 844 8812
markburgess@burmac.co.nz

SPAIN - PORTUGAL

IBB Auto Racing S.L.
C/ La Masia, 26 - Pla de les Gavarres
08711 ODENA - Igualada (Barcelona)
Tel. 902.132.124
Int. +34 938.030.880
Fax 902.124.132
Int. +34 938.055.057
info@ibbautoracing.com
www.ibbautoracing.com

SWEDEN / DENMARK

Hobby Center
S. Kyrkogatan 14
S-252 23 Helsingborg - Sweden
Tel.+46 42 131848
Fax +46 42 246328
hobby.center@tele2.se

SINGAPORE

Hobby Bounties
865 Mountbatten Road n. 02-91/92
Katong Shopping Centre
437844 Singapore
Tel: +65-6440 1890
Fax: +65-6344 1892
peter.chiang@hobbybounties.com

SWITZERLAND

Arwico AG
Brühlstasse 10 - CH-4107
Ettingen
Tel +41 617221222
Fax +41 617221242
www.arwico.ch

SOUTH AFRICA

Modelmania
Cnr South & Heuwel Road
0157 - Centurion
South Africa
Tel: +27 12 6633895
gerald@modelmania.co.za

UK - IRELAND

ABGee of Ripley Ltd
Asher House, Asher Lane Business
Park, Asher Lane, Pentrich Ripley,
Derbyshire DE5 3SW
tel 0044-1773-570444
fax 0044-1773-570888
sales@abgee.co.uk
www.abgee.co.uk

USA

Hornby America Inc.
3900-C2 Industry Dr. East
Fife, WA. 98424
Tel.+1 877-358-6405
Fax +1 253-922-7203
www.scalextric-usa.com



www.slot.it

Galileo Engineering Via Cavallotti 16 - I-42122 Reggio Emilia, Italy.

Design by www.amazingslot.com

Release January 2012