

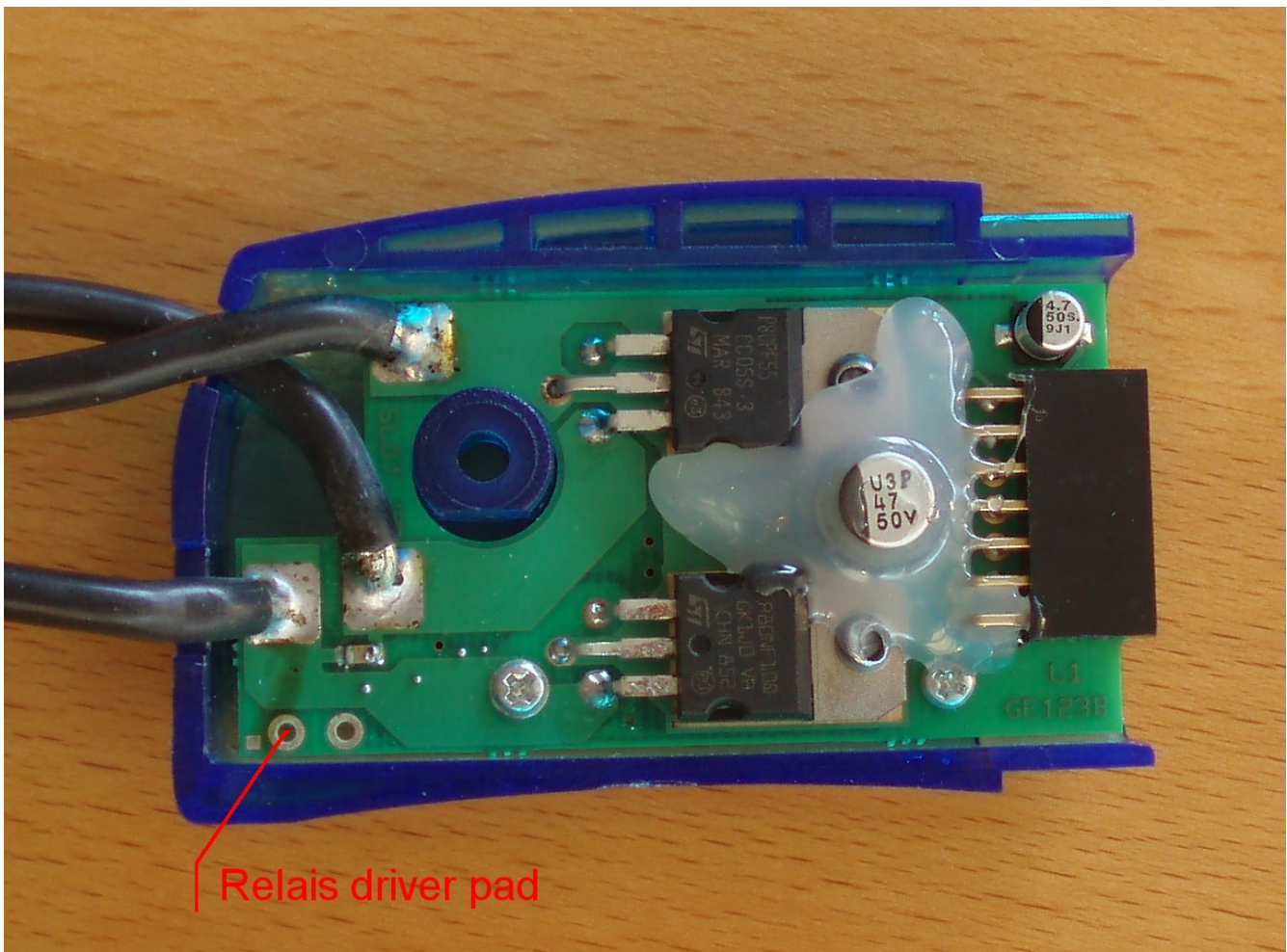

### Using an external relay in the SCP1's high current cartridge

This document applies to all SCP-1 version equipped with the 'high current' cartridge. The 'high current cartridge' can drive large currents and in addition, it was designed to drive an external relay directly.



The contact shown in the picture drives low an external relai. Use a 12V unit, with enough Ampere rating to drive your car comfortably. Please refer to the following drawing for circuit layout.

## DISCLAIMER

We are providing this information as it is. It is yours, the user's, responsibility to understand what you are doing before performing the change described below. In doubt, ask for advice. Always use a protection fuse on your power supply. Double check that the system is properly wired before applying power, in particular before connecting the relay output to the track wire. A short circuit can be a very dangerous situation, and in extreme cases destroy your controller, track, other valuable property, and even put your own life at risk. Unless you know what you are doing, ask for expert hands-on advice. This is especially true when battery power is involved.

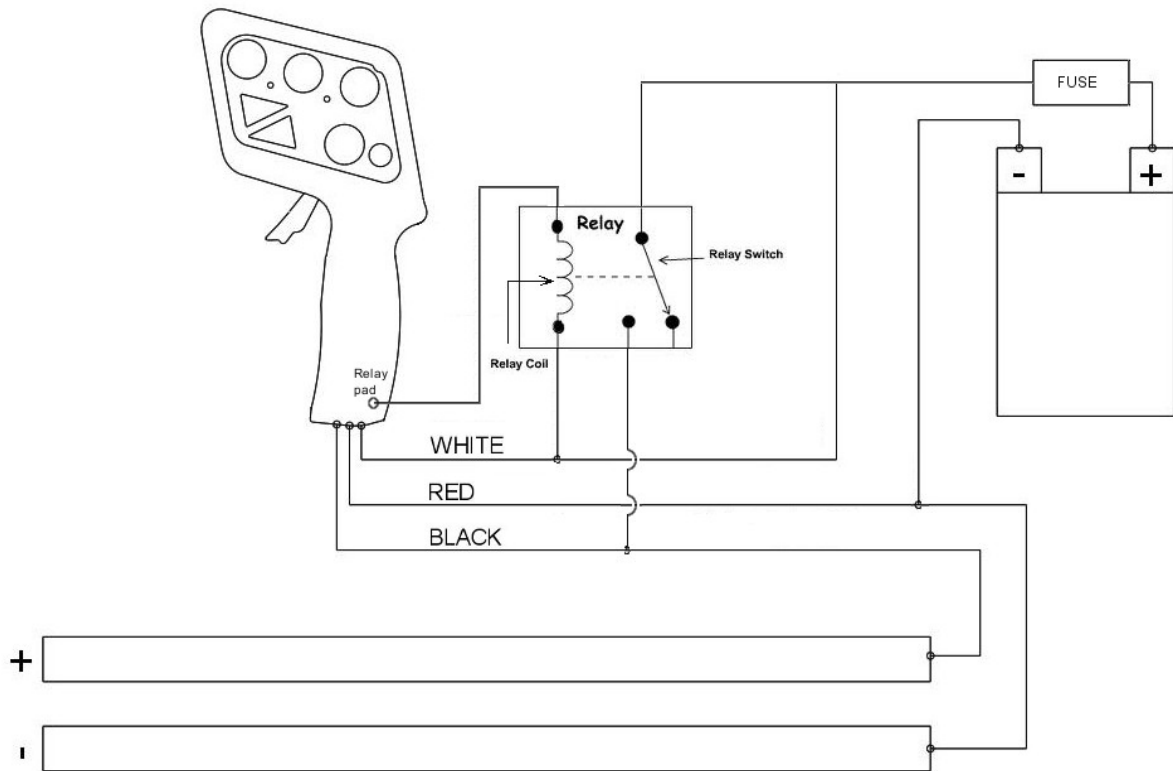

Connect the relay coil between the + of your power supply and the relay pad of the cartridge. With a Voltmeter, check carefully which one of the relay outputs is driven high (to +) when you press the trigger to 100% (you should hear the relay 'click'). Once you are sure, connect this relay output to the black (motor) wire. Leave the other output unconnected.

## WARNING

**make sure you know what you are doing**

Before connecting the relay output to the black (motor) wire, make sure the connection is properly made! If you invert the relay outputs, with the trigger released you get a straight short circuit between your power supply's positive, and the ground, running through the cartridge. You certainly don't want this to happen. A short circuit can be a very dangerous situation, and in extreme cases destroy your controller, track, other valuable property, and even put your own life at risk. Unless you know what you are doing, ask for expert hands-on advice. This is especially true when battery power is involved.