



## The Slot.it SSD compatible in-car chip SP15

The SP15 in-car chip is designed to be 100% natively compatible with Hornby's SSD digital system. It contains the original Hornby firmware: for this reason, once installed it will be just like a Hornby chip, as far as SSD is concerned. The way SSD works is not covered in this manual. Refer to SSD manual for operational instructions.

### In-car installation - SP15c

SP15c is the latest version of the Slot.it chip for Scalextric SSD systems.

The shape follows the modern Slot.it in car chip layout which is designed to fit into most modern Slot.it or Policar car with no soldering: the latest chassis design provides an area where the chip should be located, right behind the front axle. The chip should be kept in place with the provided plastic clip (left picture). There may be cases, however, where an 'inline' mounting of the chip may be useful, especially in older Slot.it cars: (bottom picture)

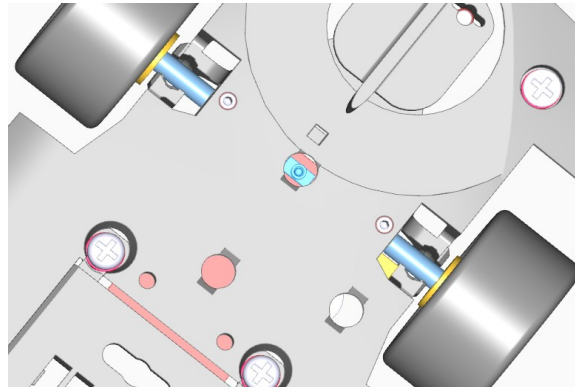
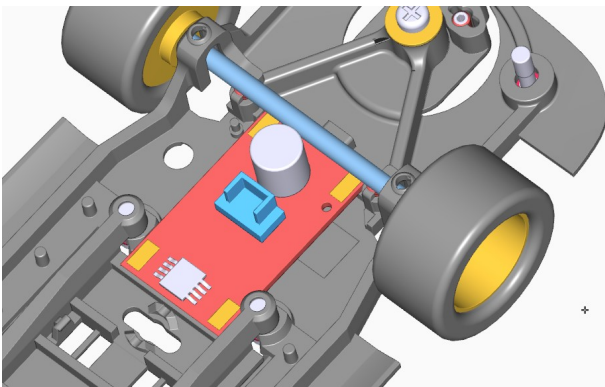
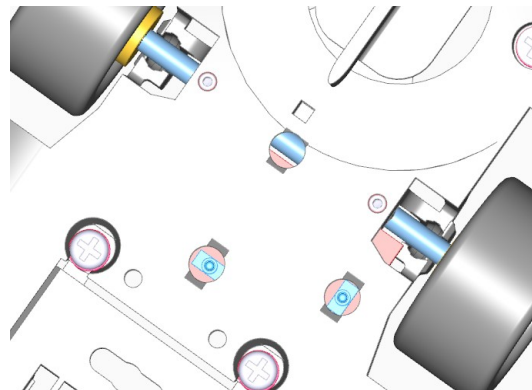
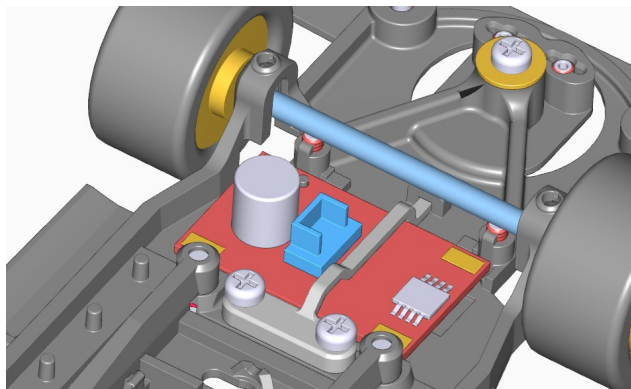

Once the chip is properly placed inside the car chassis, make sure that the LED (either one depending on the orientation) can be seen through the chassis hole. It must be aligned to the middle of the chassis.

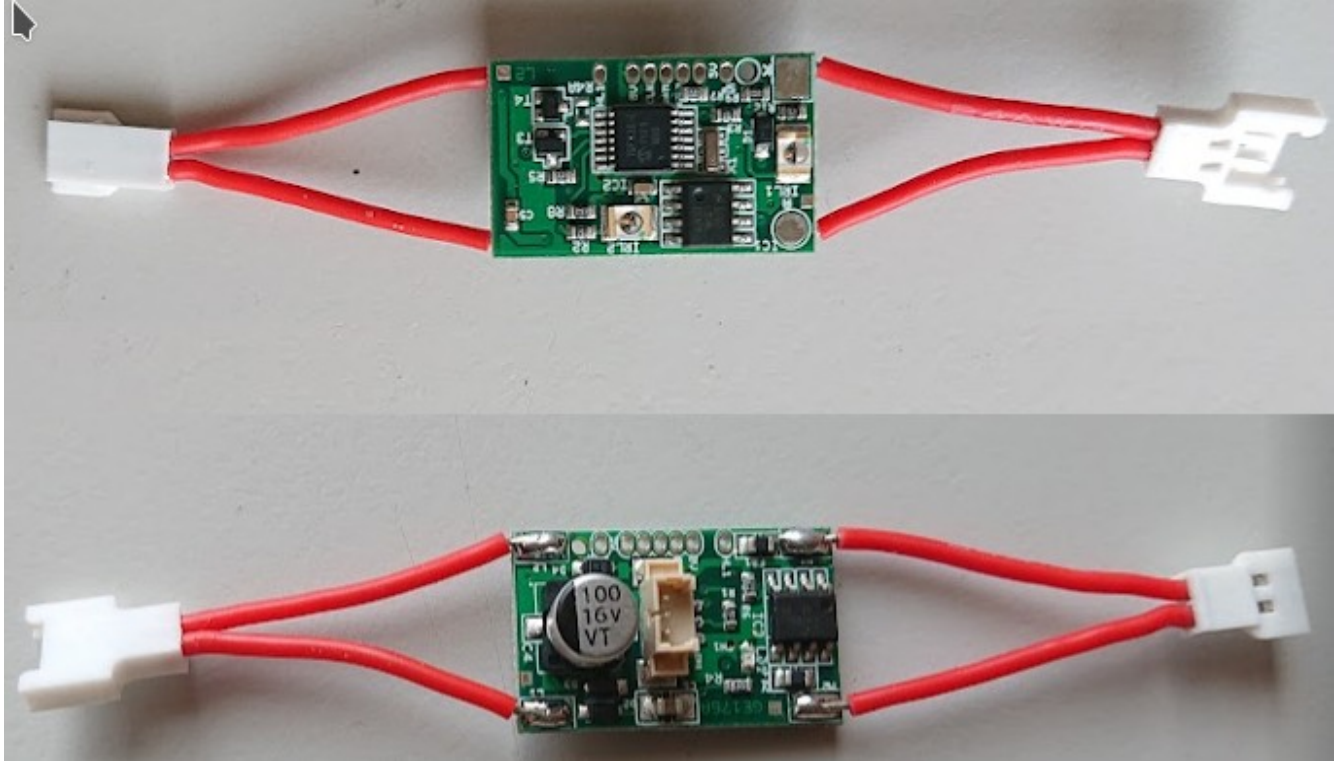

Please read the rest of this manual for further information.

## In-car installation SP15b

The SP15b can also fit on most cars.

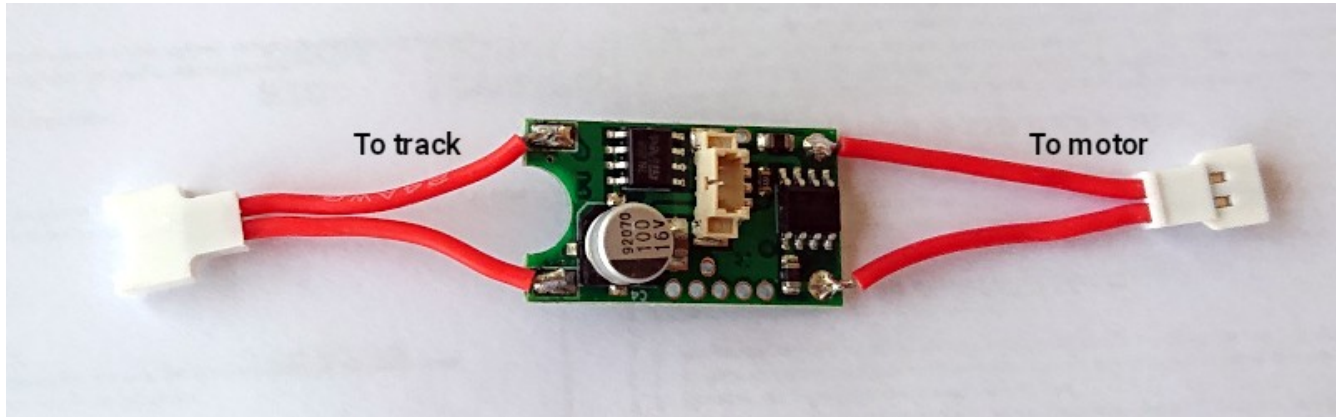

When installed in one of the latest Slot.it or Policar models, that come equipped with the now standard wires, installation is straight forward: disconnect the connectors from each other, and insert the SP15 in place:

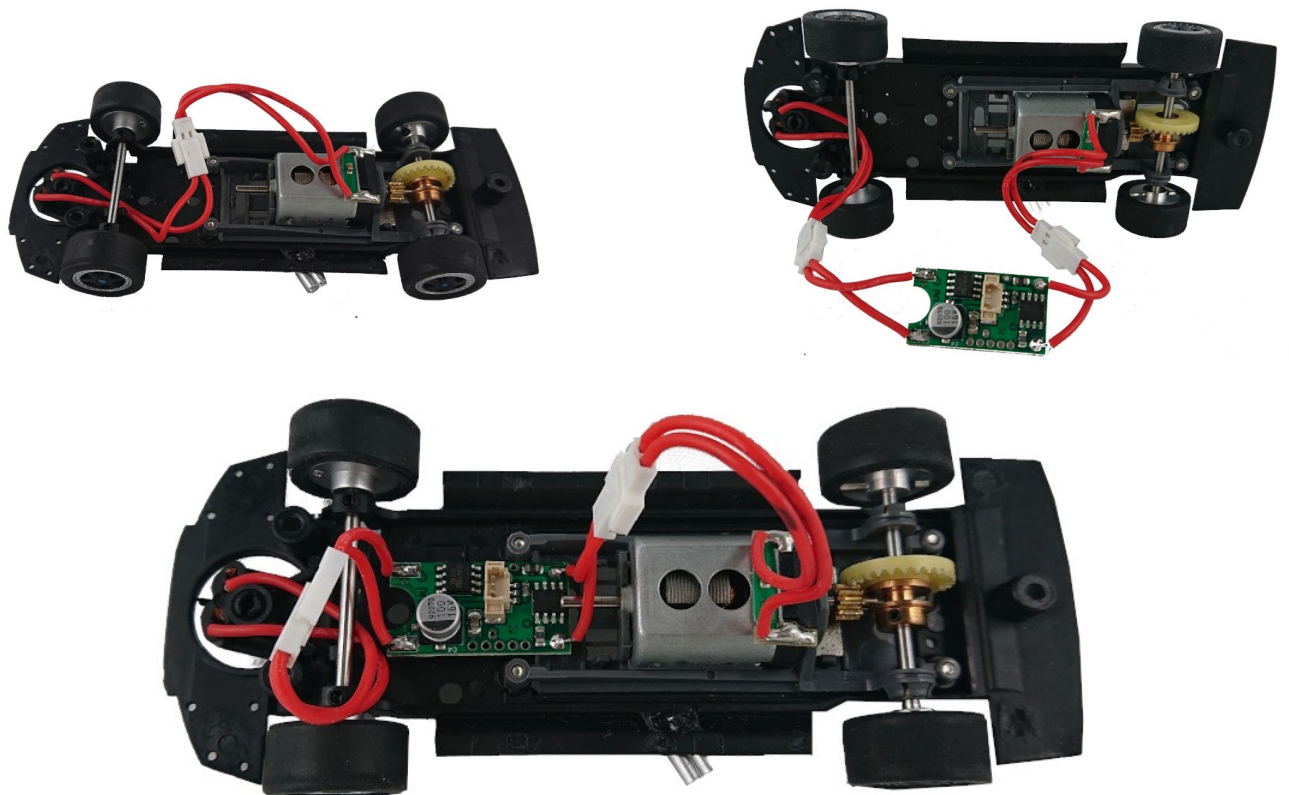

The SP15 chip has two small 'ferrites' on it, two small gray cubes located near where the motor cables are soldered. These ferrites, together with the small electronic board located on the motor (a capacitor), suppress the electrical disturbances that may alter the chip's behaviour. This is to say that in general, it

is likely that no further external component will be needed, especially on Slot.it cars.

The Slot.it motors (and many others) are also equipped with an internal noise suppression device. Unfortunately this is not true if you plan to use the SP15 on some other motors. If you experience erratic behaviour, or the SSD Power base resets when you car is nearby, you may have to install the provided 'ferrite man'.

## Say hello to Mr. FERRITE MAN

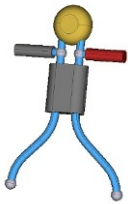

The name 'ferrite man' refers to the device made by one capacitor and one ferrite choke, which may be installed on the in-car chip wires, and that, in case must be mounted on the motor terminals. Its purpose is to suppress electrical noise coming from the motor, that may interfere with the proper working of the in-car chip. If needed, the ferrite man must be soldered according to the following pictures. On a Slot.it car, if a ferrite man must be installed, we recommend, in this



case, to remove the original capacitor on the green board where the cables are soldered to the motor itself, leaving however the green board in place

Also note that the cables are soldered between the ferrite and the capacitor, not elsewhere!

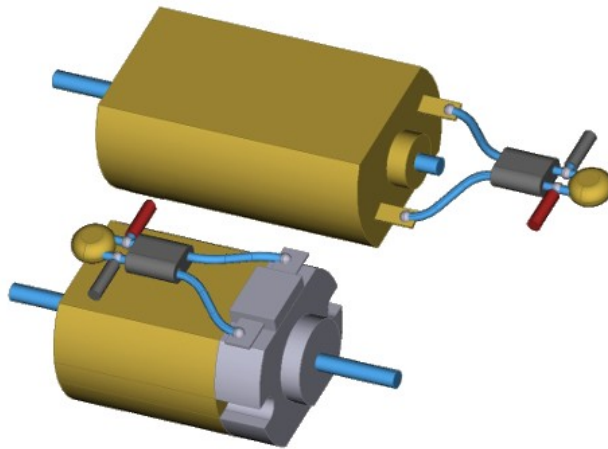

**Short circuits of any of the 'ferrite man' limbs, either between themselves, or across any metallic parts (motor edges), will damage the in-car chip. Make sure the 'limbs' stay clear of each other and of any metallic parts**



## Installing a LED on wire SP32 on SP15c/b or oXigen chip

The SP15 chip comes with a separate couple of pads that have been designed to be connected to a separate infrared LED, if necessary. The purpose of this extra LED connection is to make it possible to use a wired LED, in case the main board cannot positioned where it should with its built in LED facing downwards in the center of the chassis.

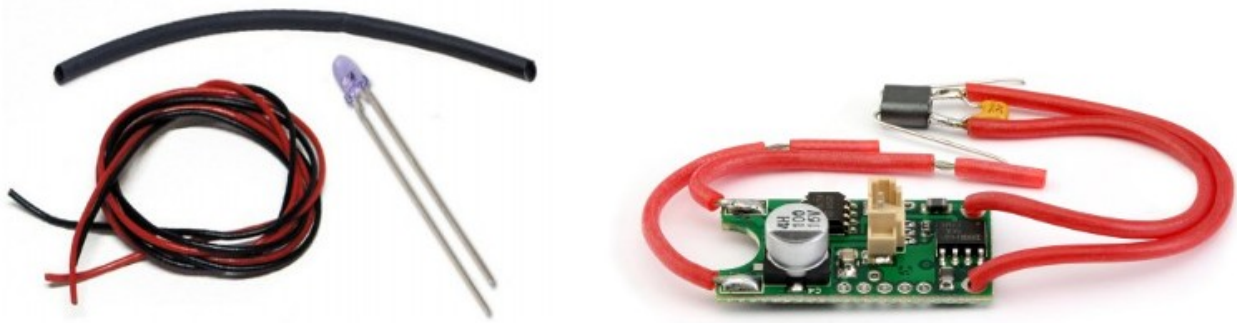

Note that the chip is designed to be used together with the specific LED supplied as SP32. We cannot guarantee that a different IR LED will work, as it may not. For the technically inclined, wavelength and forward voltage drop may prevent a third party LED from working if installed on wires.

You need a good soldering tool and some soldering skill. A good soldering station (one with a separate base, and adjustable temperature) is probably one of the best investment you can make for your slot racing toolbox. Cheap soldering irons lead to cheap results.



Please do not attempt to do this soldering with a big soldering gun, or a big tip soldering iron, as you're dealing with fine electronics and not power mains. Horses for courses.

If you have any doubts, there is a very well made [tutorial on soldering](#) at [howtogeek](#). Check it out.

This said, let's take a look at what's typically under a Slot.it in-car chip:

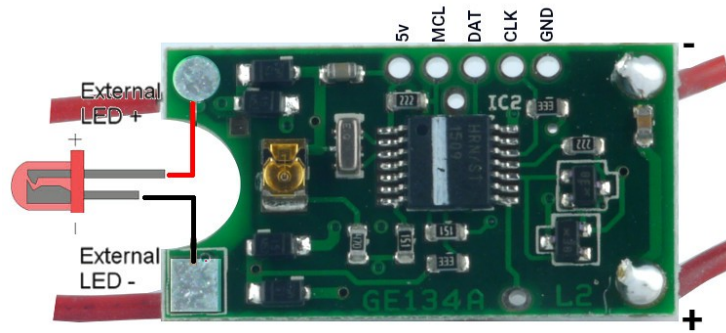

**BOTTOM VIEW**

*Typical SP15b chip*

Locate the two pads that are closer to the semi circular cut off in the circuit. One is squared, the other one is round. The square one is the LED ground and must be connected to the LED cathode, that is, the short leg of the two LED. The round one is the LED positive and must be connected to the LED anode, that is, the long leg of the LED. In general, the round LED casing is shaped to look like the one described in the oXigen chip picture above.



The sure way to break the LED is to attach it to the pads that bring power from the track. Make sure you're using the right pads (they are the ones closer to the circular cutout).

If you're using the right pads, in any case, the LED won't get damaged by a wrong polarity. If it doesn't work, reverse your soldering.

Now that you have located all your pads, and knowing what must be connected to what, you can start soldering. You will likely have to cut the LED legs short: unless you are an expert and can tell the LED polarity by its external or internal shape (you can always refer to the above picture), leave the long leg a bit longer - just in case you forget.

Now cut your wires to measure, and solder the short leg (cathode) to the black wire, and the long leg (anode) red wire. Now cut two short pieces of the heat shrinking sleeve and slide them on the wires until they cover the soldering joint that you've just made. Use the tip of the soldering iron on the heat shrink sleeve to make it shrink on your joints. This is important as it prevents short circuits and makes them much more reliable.

Solder now the black wire to the square pad, and the red wire to the round pad. Job done!